

KEY MAP

STONE HARBOR MAINTENANCE DREDGING

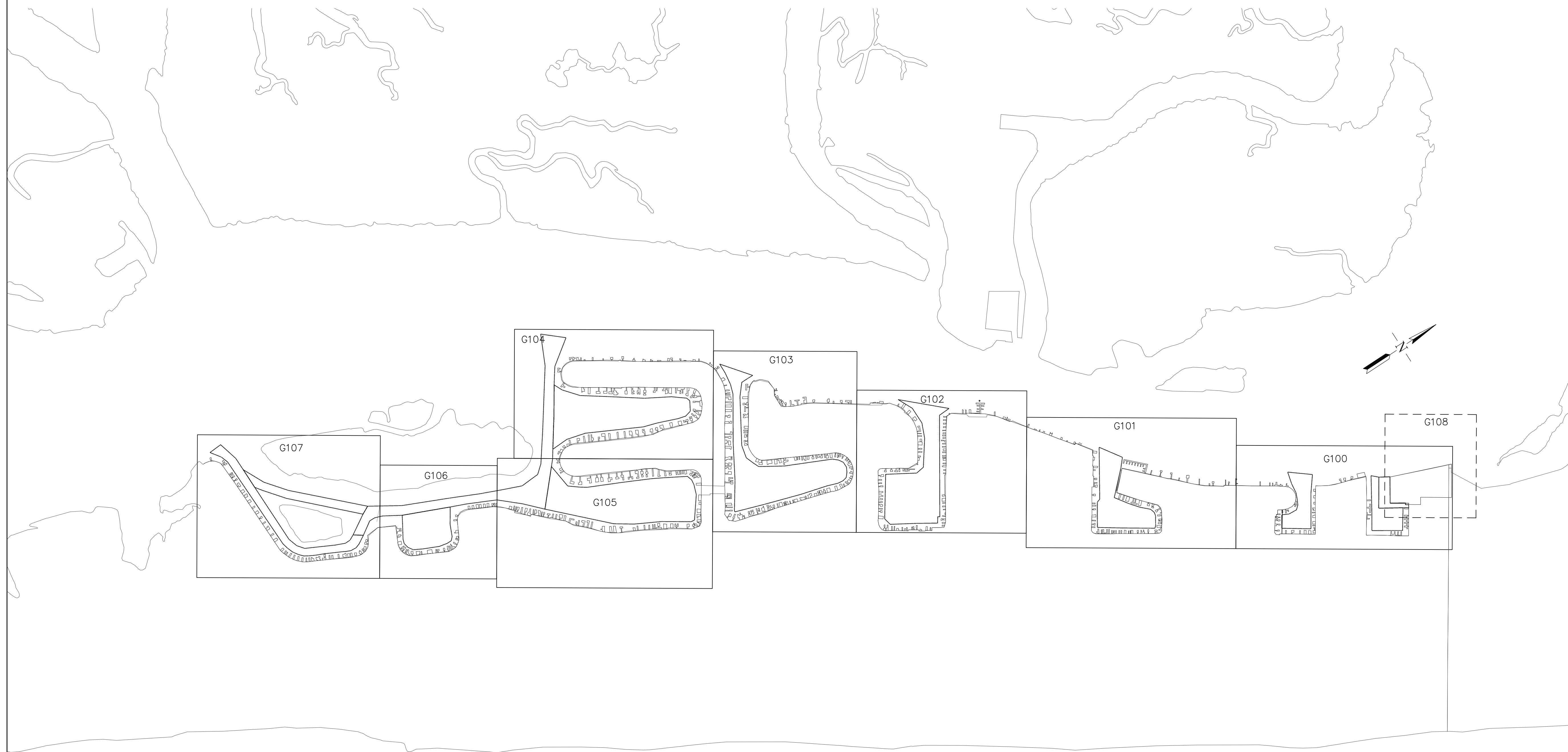

GENERAL NOTES:

1. ALL SOUNDINGS ARE IN FEET AND TENTHS AND REFER TO MEAN LOWER LOW WATER. MEAN LOWER LOW WATER IS 2.42' BELOW NAVD '88.
2. ALL SOUNDINGS ARE NEGATIVE UNLESS SHOWN WITH A PLUS (+).
3. INnersPACE 448 PRECISION SURVEY FATHOMETER USED FOR SOUNDINGS.
4. THE STARLINK DNAV 212G/MBA-2 GPS SYSTEM USED FOR POSITIONING.
5. THE HYPACK SOFTWARE USED FOR PROCESSING.
6. HYDROGRAPHIC SURVEY DATA COLLECTED BY HYDROGRAPHIC SURVEYS OF SEWELL, NJ ON 04/23/15, AND 05/01/15 AND CAN ONLY REPRESENT THE CONDITIONS AT THAT TIME.

TIDAL DIAGRAM

MEAN HIGHER HIGH WATER.....	4.57'
MEAN HIGH WATER.....	4.17'
N.A.V.D. '88.....	2.42'
N.G.V.D. '29.....	1.11'
MEAN LOW WATER.....	0.16'
MEAN LOWER LOW WATER.....	0.00'

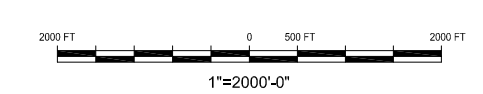

REV	DATE	DESCRIPTION	BY	CHK

CLIENT
 BOROUGH OF STONE HARBOR
 9508 SECOND AVENUE
 STONE HARBOR, NEW JERSEY

CONSULTANT
COWI Marine
 North America
 20 E. Clementon Road, Suite 201N
 Gibbstown, NJ 08026
 Website: www.cowi-na.com
 Tel.: 856.248.1200
 Fax: 856.248.1206

PROJECT TITLE
 STONE HARBOR MAINTENANCE DREDGING

ISSUED FOR BID
 DRAWING TITLE
 KEY MAP

SCALE 1" = 2000'-0"	DESIGNED MADN	APPROVED
DRAWN CAMA	CHECKED MADN	DATE 06/03/15
JOB NO. A067772	DRAWING NO. G000	REV.

FILE LOCATION: C:\A067772\G000\TASK\A067772-G000-G107.DWG

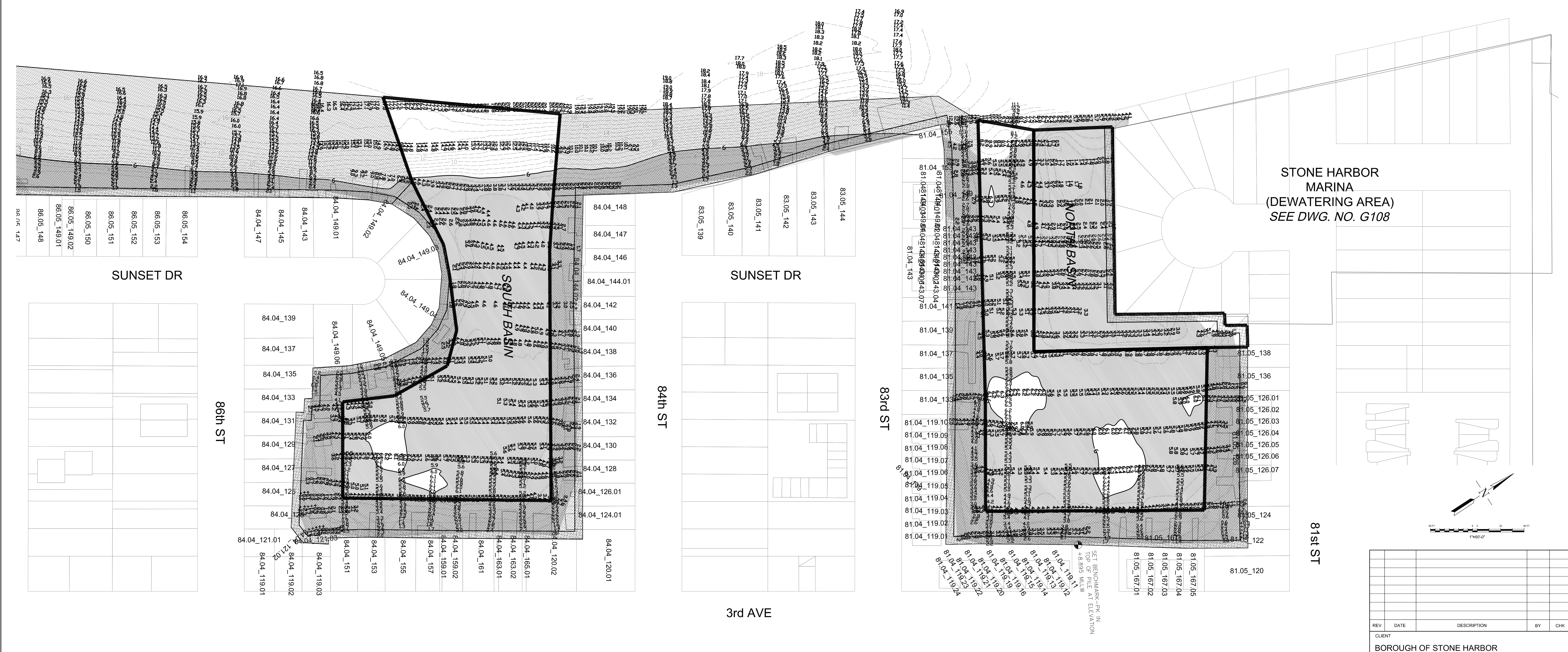

NOTES:

1. HYDROGRAPHIC SURVEY DATA COLLECTED BY HYDROGRAPHIC SURVEYS OF SEWELL, NJ BETWEEN 04/23/2015 AND 05/01/2015 AND CAN ONLY REPRESENT THE CONDITIONS AT THE TIME OF SURVEY.
2. NO DREDGING SHALL OCCUR WITHIN 10 FEET OF THE BULKHEAD.
3. NO DREDGING SHALL OCCUR WITHIN 25 FEET OF WETLANDS.
4. ALL MAINTENANCE DREDGING SHALL HAVE 3:1 (H:V) SIDE SLOPE FROM LIMITS OF DREDGING AND BUFFER AREAS.
5. ALL PROPERTY BOUNDARIES AND FEATURES HAVE BEEN PRODUCED FROM VARIOUS SOURCES AND IS TO BE USED FOR REFERENCE PURPOSES ONLY. THE DATA IS FOR INFORMATIONAL PURPOSES ONLY AND REPRESENTS ONLY THE APPROXIMATE RELATIVE LOCATION OF PROPERTY BOUNDARIES AND FEATURES. CONTRACTOR TO VERIFY IN FIELD.
6. SLIP DREDGING AREA EXTENDS BETWEEN BOROUGH DREDGING LIMITS AND BULKHEAD.

LEGEND:

- DEPTH LESS THAN 6 FT
- WETLAND VEGETATION (AS OF MAY 2015)
- BUFFER AREA (10 FT FROM BULKHEAD, 25 FT FROM WETLANDS)
- PARCEL
- BULKHEAD
- BOROUGH DREDGING LIMIT
- SLIP DREDGING LIMIT (N.I.C.)
- DESIGN DREDGE DEPTH (6 FT MLLW CONTOUR)
- CONTOURS (1 FT INTERVAL)

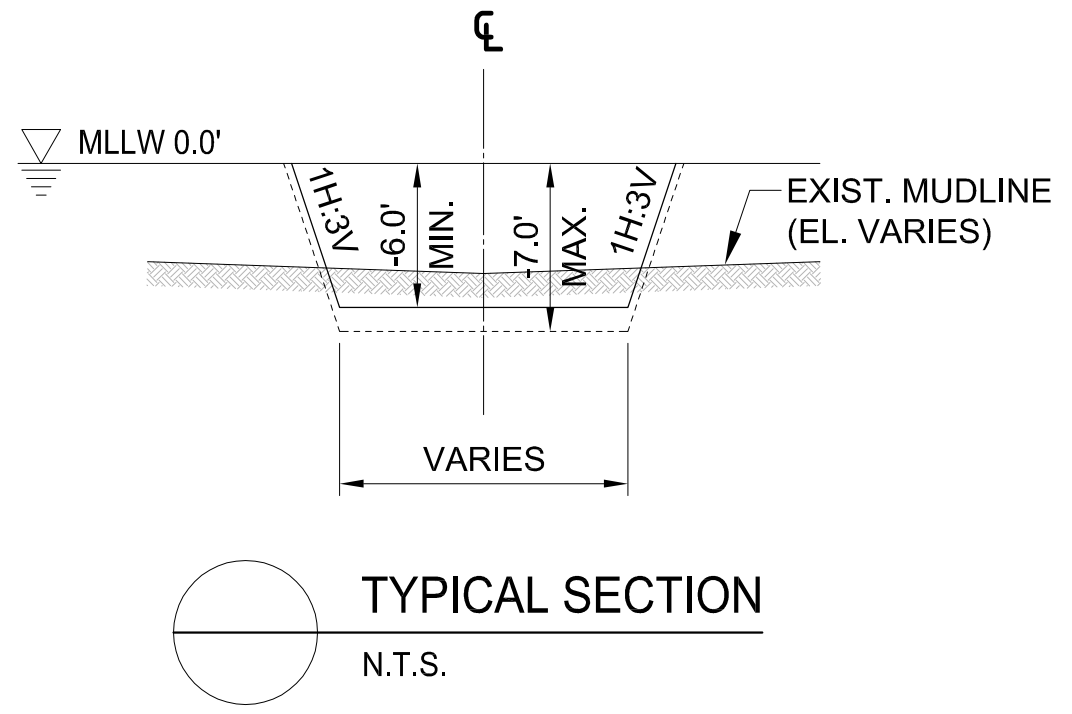

REV	DATE	DESCRIPTION	BY	CHK
CLIENT BOROUGH OF STONE HARBOR 9508 SECOND AVENUE STONE HARBOR, NEW JERSEY				
CONSULTANT COWI Marine North America 20 E. Clementon Road, Suite 201N Gibbstown, NJ 08026 Tel.: 856.248.1200 Fax: 856.248.1206 Website: www.cowi-na.com				
PROJECT TITLE STONE HARBOR MAINTENANCE DREDGING				
ISSUED FOR BID DRAWING TITLE SOUTH BASIN AND NORTH BASIN				
SCALE 1" = 60'-0"	DESIGNED MADN	APPROVED		
DRAWN CAMA	CHECKED MADN	DATE 06/03/15		
JOB NO. A067772	DRAWING NO. G100	REV.		

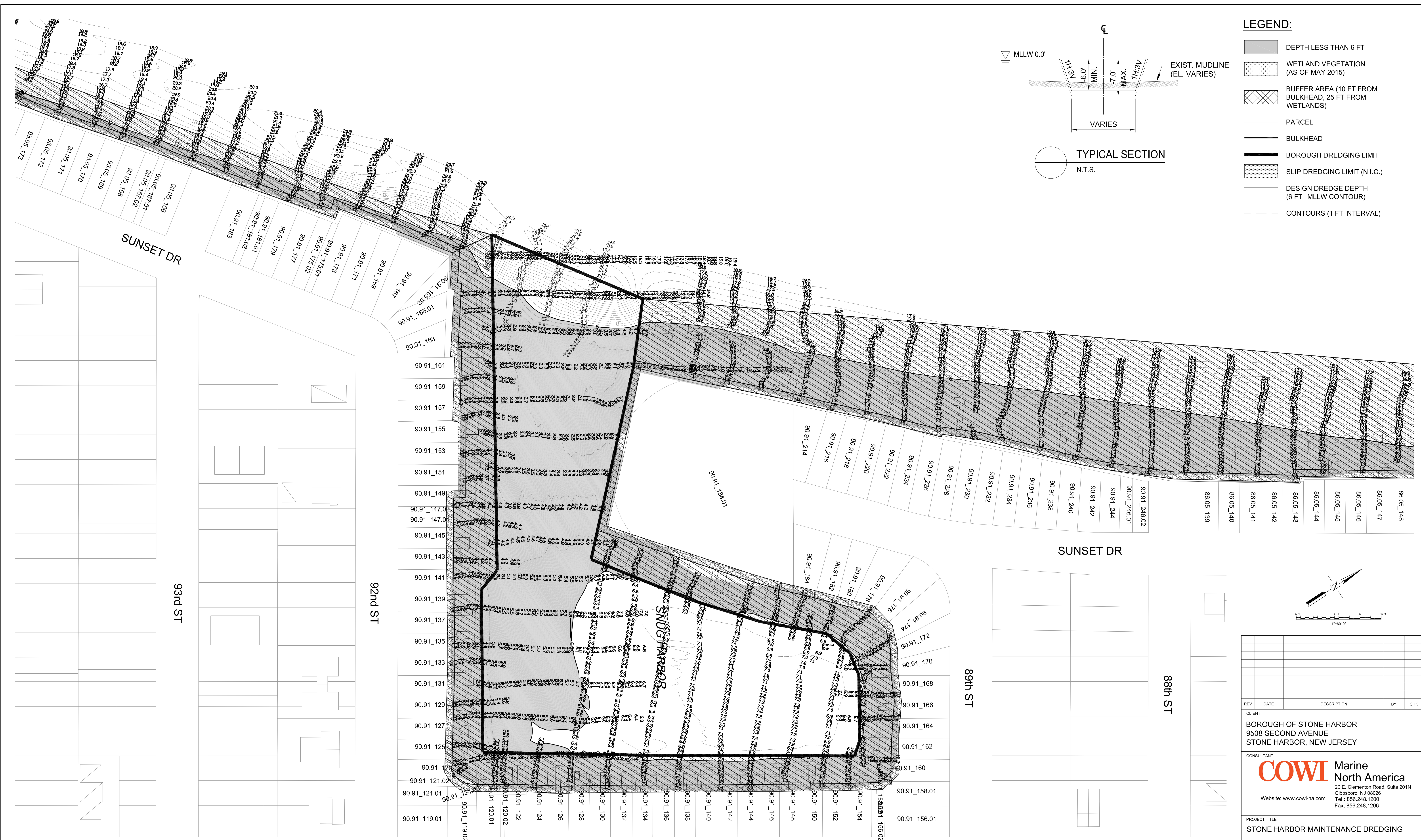

- LEGEND:**
- DEPTH LESS THAN 6 FT
 - WETLAND VEGETATION (AS OF MAY 2015)
 - BUFFER AREA (10 FT FROM BULKHEAD, 25 FT FROM WETLANDS)
 - PARCEL
 - BULKHEAD
 - BOROUGH DREDGING LIMIT
 - SLIP DREDGING LIMIT (N.I.C.)
 - DESIGN DREDGE DEPTH (6 FT MLLW CONTOUR)
 - CONTOURS (1 FT INTERVAL)

TYPICAL SECTION
N.T.S.

REV	DATE	DESCRIPTION	BY	CHK
CLIENT				
BOROUGH OF STONE HARBOR 9508 SECOND AVENUE STONE HARBOR, NEW JERSEY				
CONSULTANT				
20 E. Clementon Road, Suite 201N Gibbsboro, NJ 08026 Tel.: 856.248.1200 Fax: 856.248.1206				
PROJECT TITLE				
STONE HARBOR MAINTENANCE DREDGING				
ISSUED FOR BID				
DRAWING TITLE				
SNUG HARBOR				
SCALE	DESIGNED	APPROVED		
1" = 60'-0"	MADN			
DRAWN	CHECKED	DATE		
CAMA	MADN	06/03/15		
JOB NO.	DRAWING NO.	REV.		
A067772	G101			

- NOTES:**
1. HYDROGRAPHIC SURVEY DATA COLLECTED BY HYDROGRAPHIC SURVEYS OF SEWELL, NJ BETWEEN 04/23/2015 AND 05/01/2015 AND CAN ONLY REPRESENT THE CONDITIONS AT THE TIME OF SURVEY.
 2. NO DREDGING SHALL OCCUR WITHIN 10 FEET OF THE BULKHEAD.
 3. NO DREDGING SHALL OCCUR WITHIN 25 FEET OF WETLANDS.
 4. ALL MAINTENANCE DREDGING SHALL HAVE 3:1 (H:V) SIDE SLOPE FROM LIMITS OF DREDGING AND BUFFER AREAS.

5. ALL PROPERTY BOUNDARIES AND FEATURES HAVE BEEN PRODUCED FROM VARIOUS SOURCES AND IS TO BE USED FOR REFERENCE PURPOSES ONLY. THE DATA IS FOR INFORMATIONAL PURPOSES ONLY AND REPRESENTS ONLY THE APPROXIMATE RELATIVE LOCATION OF PROPERTY BOUNDARIES AND FEATURES. CONTRACTOR TO VERIFY IN FIELD.
6. SLIP DREDGING AREA EXTENDS BETWEEN BOROUGH DREDGING LIMITS AND BULKHEAD.

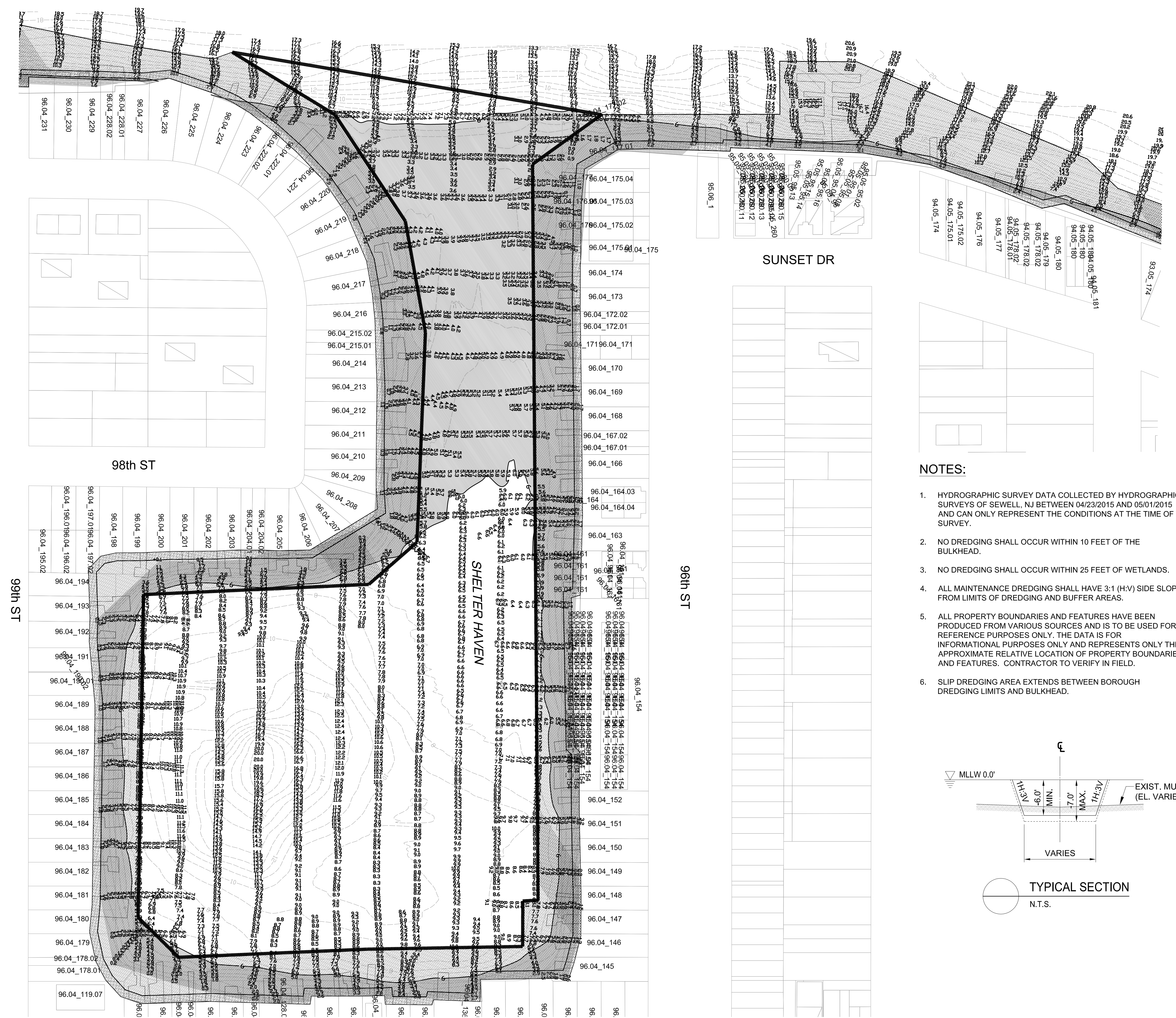

- LEGEND:**
- DEPTH LESS THAN 6 FT
 - WETLAND VEGETATION (AS OF MAY 2015)
 - BUFFER AREA (10 FT FROM BULKHEAD, 25 FT FROM WETLANDS)
 - PARCEL
 - BULKHEAD
 - BOROUGH DREDGING LIMIT
 - SLIP DREDGING LIMIT (N.I.C.)
 - DESIGN DREDGE DEPTH (6 FT MLLW CONTOUR)
 - CONTOURS (1 FT INTERVAL)

NOTES:

1. HYDROGRAPHIC SURVEY DATA COLLECTED BY HYDROGRAPHIC SURVEYS OF SEWELL, NJ BETWEEN 04/23/2015 AND 05/01/2015 AND CAN ONLY REPRESENT THE CONDITIONS AT THE TIME OF SURVEY.
2. NO DREDGING SHALL OCCUR WITHIN 10 FEET OF THE BULKHEAD.
3. NO DREDGING SHALL OCCUR WITHIN 25 FEET OF WETLANDS.
4. ALL MAINTENANCE DREDGING SHALL HAVE 3:1 (H:V) SIDE SLOPE FROM LIMITS OF DREDGING AND BUFFER AREAS.
5. ALL PROPERTY BOUNDARIES AND FEATURES HAVE BEEN PRODUCED FROM VARIOUS SOURCES AND IS TO BE USED FOR INFORMATIONAL PURPOSES ONLY AND REPRESENTS ONLY THE APPROXIMATE RELATIVE LOCATION OF PROPERTY BOUNDARIES AND FEATURES. CONTRACTOR TO VERIFY IN FIELD.
6. SLIP DREDGING AREA EXTENDS BETWEEN BOROUGH DREDGING LIMITS AND BULKHEAD.

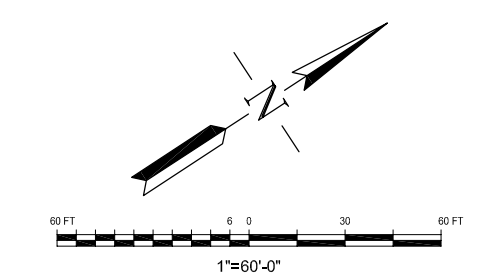
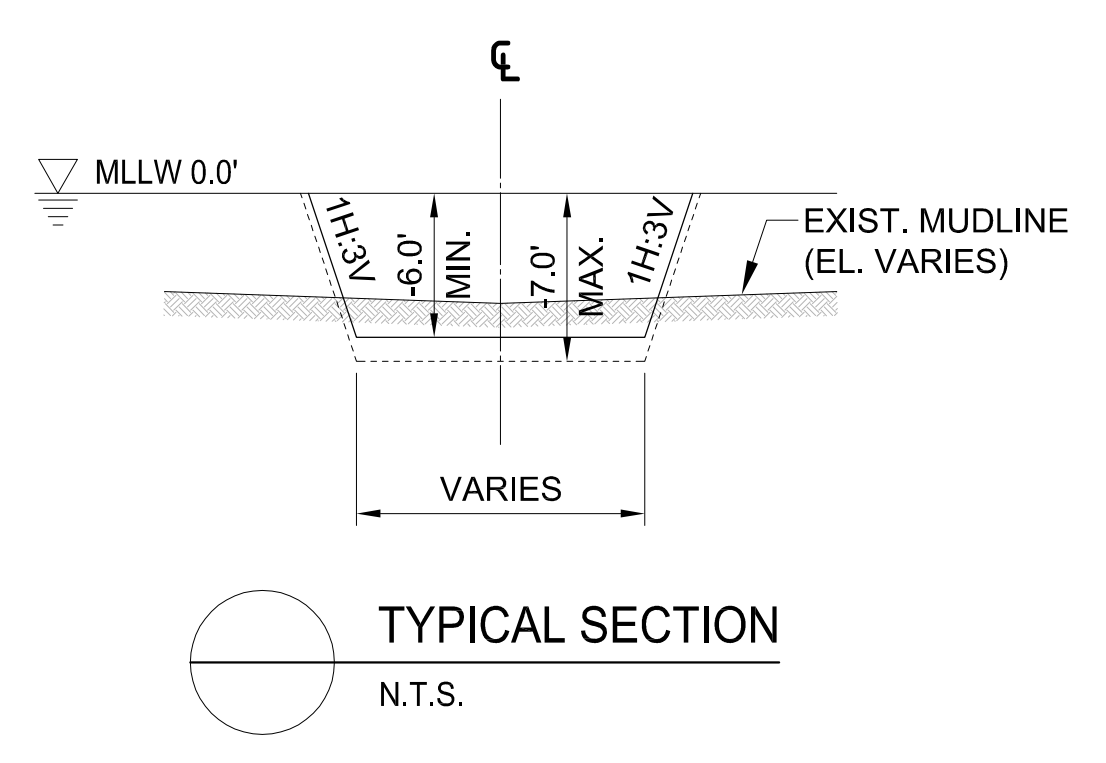

REV	DATE	DESCRIPTION	BY	CHK
CLIENT				
BOROUGH OF STONE HARBOR 9508 SECOND AVENUE STONE HARBOR, NEW JERSEY				
CONSULTANT				
20 E. Clementon Road, Suite 201N Gibbsboro, NJ 08026 Tel.: 856.248.1200 Fax: 856.248.1206 Website: www.cowi-na.com				
PROJECT TITLE				
STONE HARBOR MAINTENANCE DREDGING				
ISSUED FOR BID				
DRAWING TITLE				
SHELTER HAVEN				
SCALE	DESIGNED	APPROVED		
1" = 60'-0"	MADN			
DRAWN	CHECKED	DATE		
CAMA	MADN	06/03/15		
JOB NO.	DRAWING NO.	REV.		
A067772	G102			

FILE LOCATION: C:\A060000\A067772\TASK 24\A067772-G000-G102.DWG

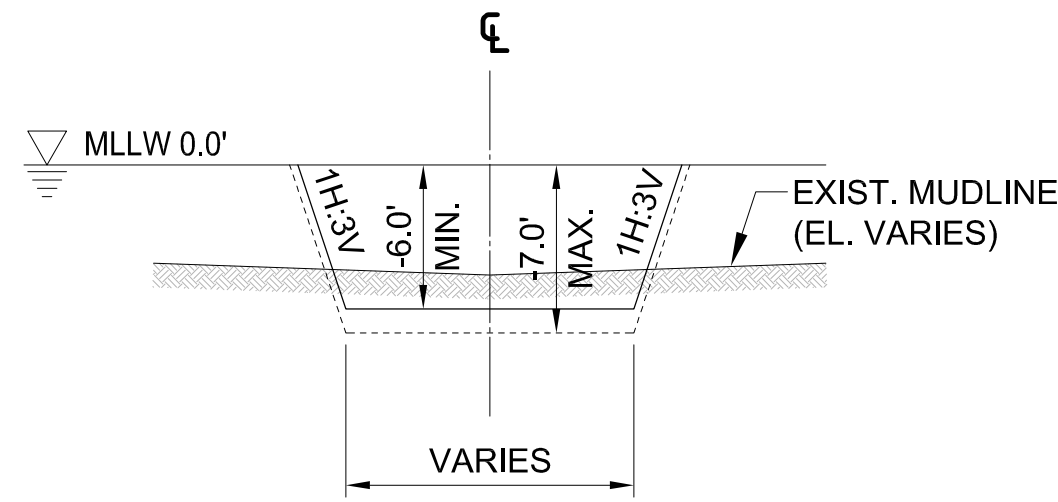

TYPICAL SECTION
N.T.S.

- NOTES:**
1. HYDROGRAPHIC SURVEY DATA COLLECTED BY HYDROGRAPHIC SURVEYS OF SEWELL, NJ BETWEEN 04/23/2015 AND 05/01/2015 AND CAN ONLY REPRESENT THE CONDITIONS AT THE TIME OF SURVEY.
 2. NO DREDGING SHALL OCCUR WITHIN 10 FEET OF THE BULKHEAD.
 3. NO DREDGING SHALL OCCUR WITHIN 25 FEET OF WETLANDS.
 4. ALL MAINTENANCE DREDGING SHALL HAVE 3:1 (H:V) SIDE SLOPE FROM LIMITS OF DREDGING AND BUFFER AREAS.
 5. ALL PROPERTY BOUNDARIES AND FEATURES HAVE BEEN PRODUCED FROM VARIOUS SOURCES AND IS TO BE USED FOR REFERENCE PURPOSES ONLY. THE DATA IS FOR INFORMATIONAL PURPOSES ONLY AND REPRESENTS ONLY THE APPROXIMATE RELATIVE LOCATION OF PROPERTY BOUNDARIES AND FEATURES. CONTRACTOR TO VERIFY IN FIELD.
 6. SLIP DREDGING AREA EXTENDS BETWEEN BOROUGH DREDGING LIMITS AND BULKHEAD.

- LEGEND:**
- DEPTH LESS THAN 6 FT
 - WETLAND VEGETATION (AS OF MAY 2015)
 - BUFFER AREA (10 FT FROM BULKHEAD, 25 FT FROM WETLANDS)
 - PARCEL
 - BULKHEAD
 - BOROUGH DREDGING LIMIT
 - SLIP DREDGING LIMIT (N.I.C.)
 - DESIGN DREDGE DEPTH (6 FT MLLW CONTOUR)
 - CONTOURS (1 FT INTERVAL)

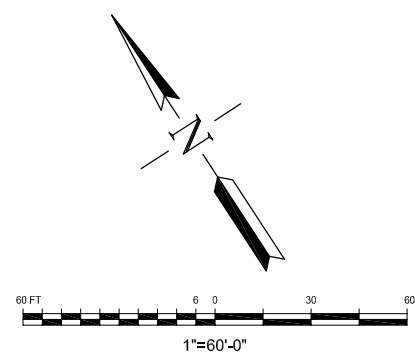

REV	DATE	DESCRIPTION	BY	CHK
CLIENT				
BOROUGH OF STONE HARBOR 9508 SECOND AVENUE STONE HARBOR, NEW JERSEY				
CONSULTANT				
COWI		Marine North America		
		20 E. Clementon Road, Suite 201N Gibbsboro, NJ 08026 Tel.: 856.248.1200 Fax: 856.248.1206		
PROJECT TITLE				
STONE HARBOR MAINTENANCE DREDGING				
ISSUED FOR BID				
DRAWING TITLE				
STONE HARBOR				
SCALE	DESIGNED	APPROVED		
1" = 60'-0"	MADN			
DRAWN	CHECKED	DATE		
CAMA	MADN	06/03/15		
JOB NO.	DRAWING NO.	REV.		
A067772	G103			

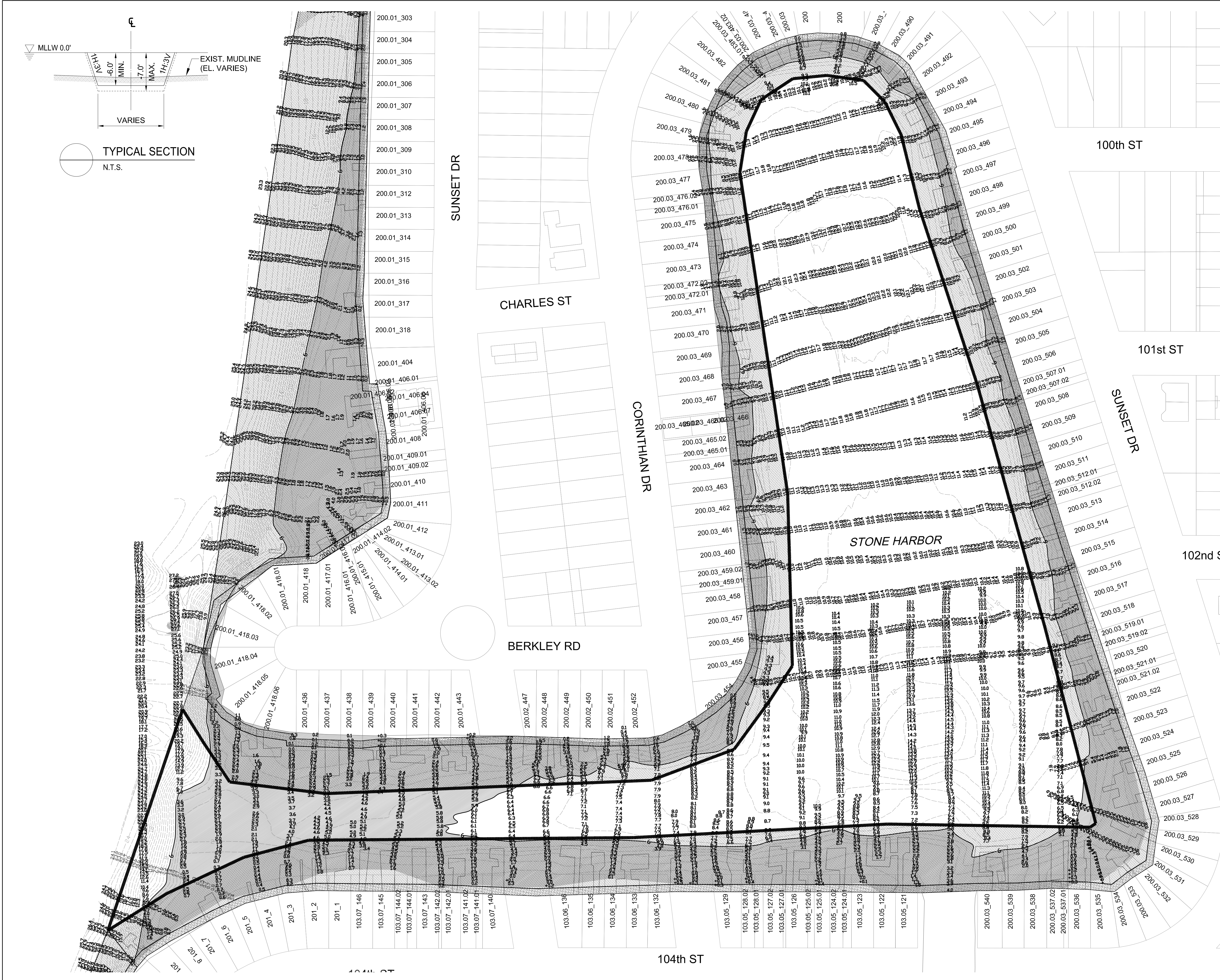

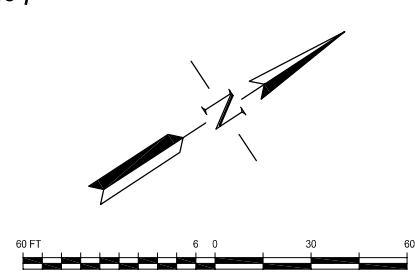
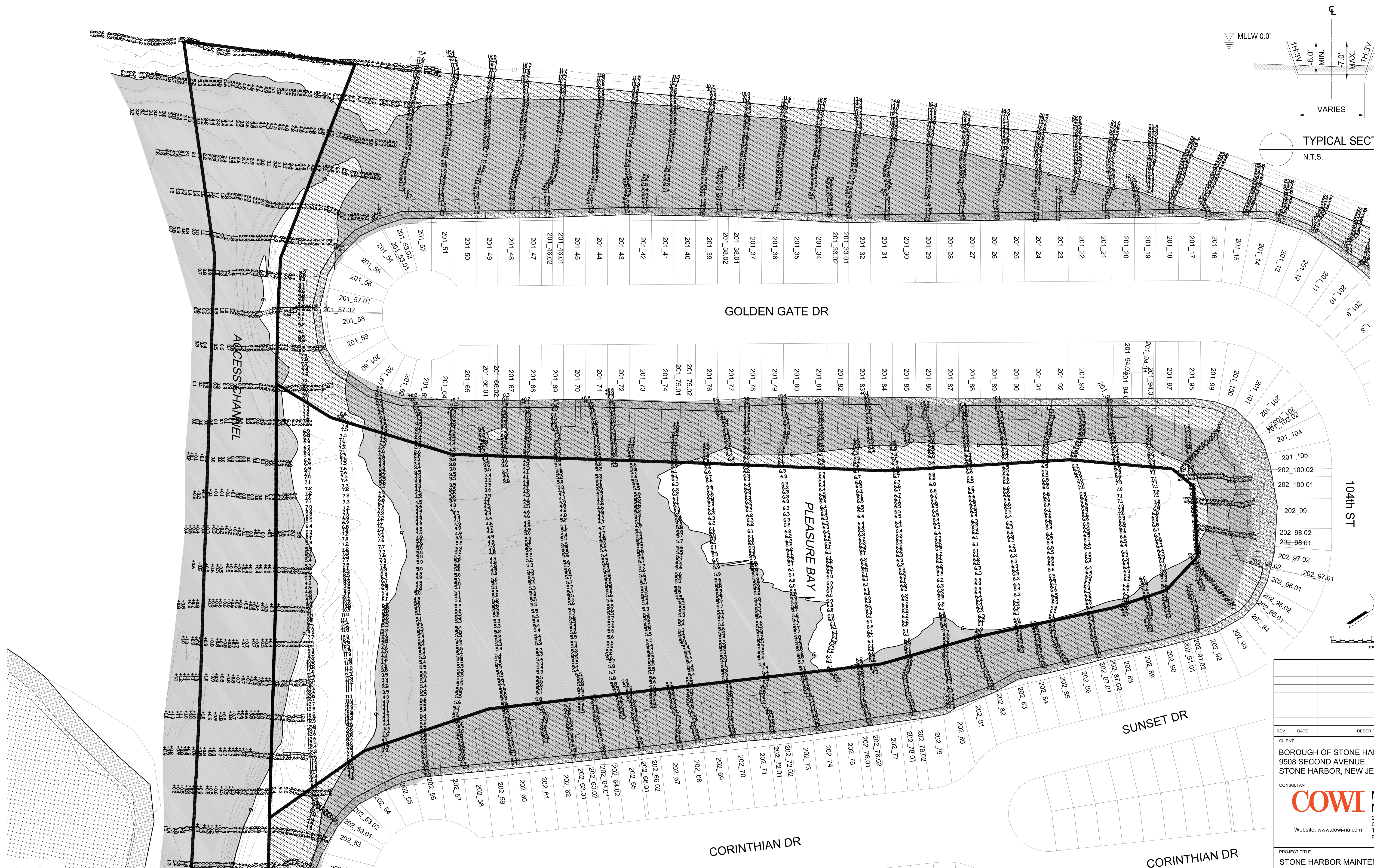
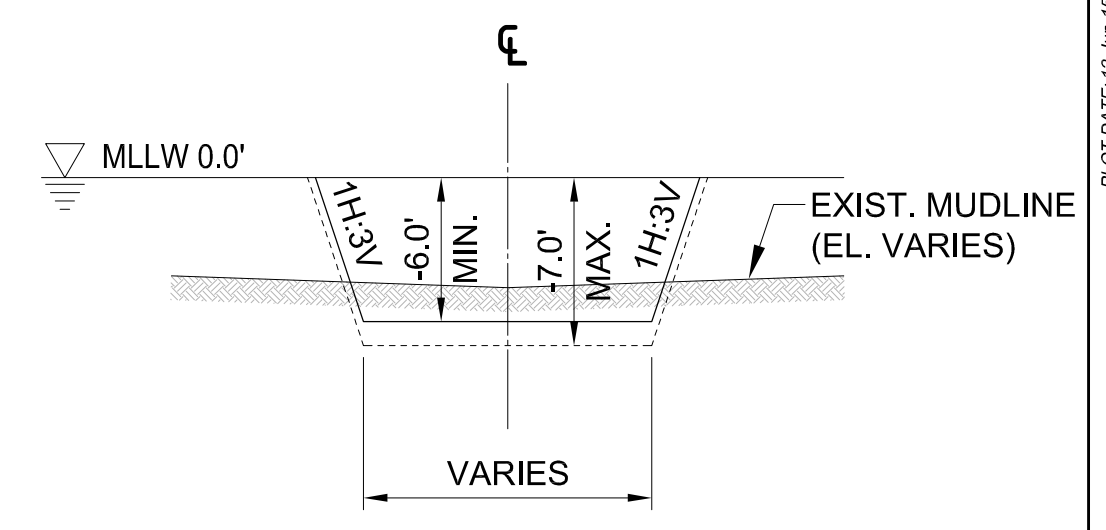

- NOTES:**
1. HYDROGRAPHIC SURVEY DATA COLLECTED BY HYDROGRAPHIC SURVEYS OF SEWELL, NJ BETWEEN 04/23/2015 AND 05/01/2015 AND CAN ONLY REPRESENT THE CONDITIONS AT THE TIME OF SURVEY.
 2. NO DREDGING SHALL OCCUR WITHIN 10 FEET OF THE BULKHEAD.
 3. NO DREDGING SHALL OCCUR WITHIN 25 FEET OF WETLANDS.
 4. ALL MAINTENANCE DREDGING SHALL HAVE 3:1 (H:V) SIDE SLOPE FROM LIMITS OF DREDGING AND BUFFER AREAS.
 5. ALL PROPERTY BOUNDARIES AND FEATURES HAVE BEEN PRODUCED FROM VARIOUS SOURCES AND IS TO BE USED FOR REFERENCE PURPOSES ONLY. THE DATA IS FOR INFORMATIONAL PURPOSES ONLY AND REPRESENTS ONLY THE APPROXIMATE RELATIVE LOCATION OF PROPERTY BOUNDARIES AND FEATURES. CONTRACTOR TO VERIFY IN FIELD.
 6. SLIP DREDGING AREA EXTENDS BETWEEN BOROUGH DREDGING LIMITS AND BULKHEAD.

- LEGEND:**
- DEPTH LESS THAN 6 FT
 - WETLAND VEGETATION (AS OF MAY 2015)
 - BUFFER AREA (10 FT FROM BULKHEAD, 25 FT FROM WETLANDS)
 - PARCEL
 - BULKHEAD
 - BOROUGH DREDGING LIMIT
 - SLIP DREDGING LIMIT (N.I.C.)
 - DESIGN DREDGE DEPTH (6 FT MLLW CONTOUR)
 - CONTOURS (1 FT INTERVAL)

REV	DATE	DESCRIPTION	BY	CHK
CLIENT				
BOROUGH OF STONE HARBOR 9508 SECOND AVENUE STONE HARBOR, NEW JERSEY				
CONSULTANT				
COWI Marine North America				
20 E. Clementon Road, Suite 201N Gibbsboro, NJ 08026 Tel.: 856.248.1200 Fax: 856.248.1206 Website: www.cowi-na.com				
PROJECT TITLE				
STONE HARBOR MAINTENANCE DREDGING				
ISSUED FOR BID				
DRAWING TITLE				
PLEASURE BAY AND ACCESS CHANNEL				
SCALE	DESIGNED	APPROVED		
1" = 60'-0"	MADN			
DRAWN	CHECKED	DATE		
CAMA	MADN	06/03/15		
JOB NO.	DRAWING NO.	REV.		
A067772	G104			





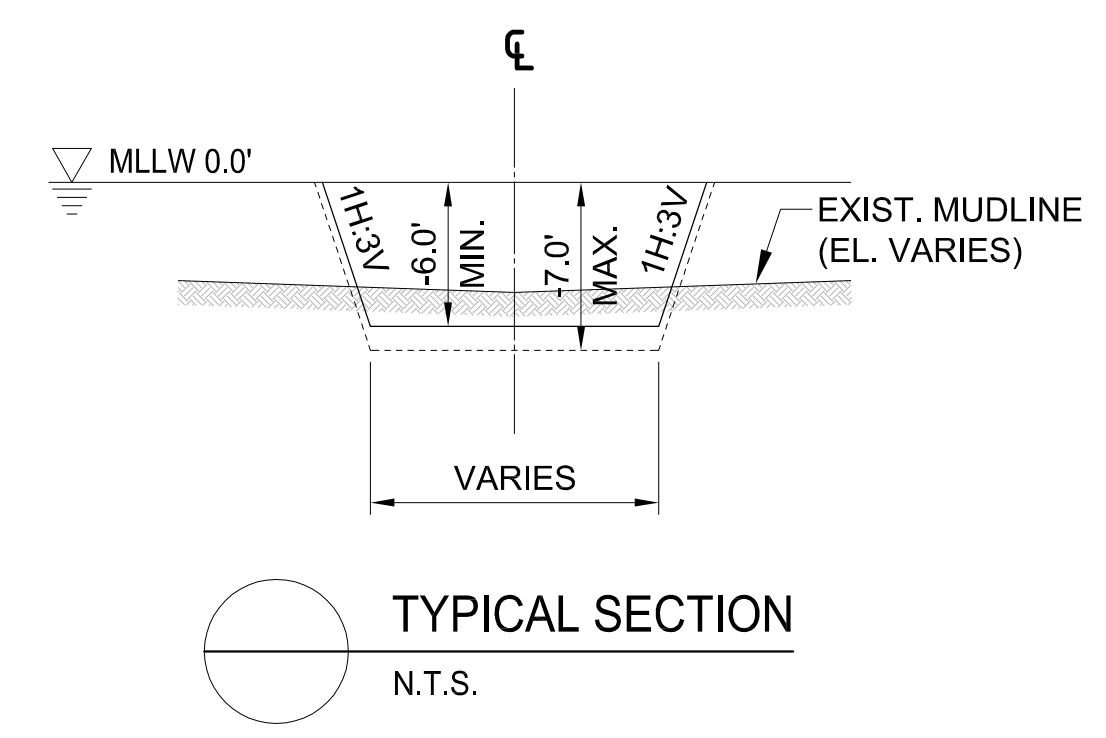

- NOTES:**
1. HYDROGRAPHIC SURVEY DATA COLLECTED BY HYDROGRAPHIC SURVEYS OF SEWELL, NJ BETWEEN 04/23/2015 AND 05/01/2015 AND CAN ONLY REPRESENT THE CONDITIONS AT THE TIME OF SURVEY.
 2. NO DREDGING SHALL OCCUR WITHIN 10 FEET OF THE BULKHEAD.
 3. NO DREDGING SHALL OCCUR WITHIN 25 FEET OF WETLANDS.
 4. ALL MAINTENANCE DREDGING SHALL HAVE 3:1 (H:V) SIDE SLOPE FROM LIMITS OF DREDGING AND BUFFER AREAS.
 5. ALL PROPERTY BOUNDARIES AND FEATURES HAVE BEEN PRODUCED FROM VARIOUS SOURCES AND IS TO BE USED FOR REFERENCE PURPOSES ONLY. THE DATA IS FOR INFORMATIONAL PURPOSES ONLY AND REPRESENTS ONLY THE APPROXIMATE RELATIVE LOCATION OF PROPERTY BOUNDARIES AND FEATURES. CONTRACTOR TO VERIFY IN FIELD.
 6. SLIP DREDGING AREA EXTENDS BETWEEN BOROUGH DREDGING LIMITS AND BULKHEAD.

- LEGEND:**
- DEPTH LESS THAN 6 FT
 - WETLAND VEGETATION (AS OF MAY 2015)
 - BUFFER AREA (10 FT FROM BULKHEAD, 25 FT FROM WETLANDS)
 - PARCEL
 - BULKHEAD
 - BOROUGH DREDGING LIMIT
 - SLIP DREDGING LIMIT (N.I.C.)
 - DESIGN DREDGE DEPTH (6 FT MLLW CONTOUR)
 - CONTOURS (1 FT INTERVAL)

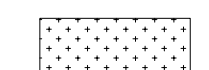
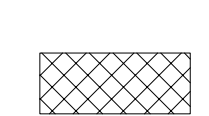

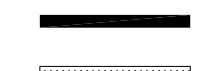
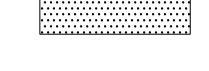

REV	DATE	DESCRIPTION	BY	CHK
CLIENT				
BOROUGH OF STONE HARBOR 9508 SECOND AVENUE STONE HARBOR, NEW JERSEY				
CONSULTANT				
COWI		Marine North America		
20 E. Clementon Road, Suite 201N Gibbsboro, NJ 08026 Tel.: 856.248.1200 Fax: 856.248.1206 Website: www.cowi-na.com				
PROJECT TITLE				
STONE HARBOR MAINTENANCE DREDGING				
ISSUED FOR BID				
DRAWING TITLE				
CARNIVAL BAY AND ACCESS CHANNEL				
SCALE	DESIGNED	APPROVED		
1" = 60'-0"	MADN			
DRAWN	CHECKED	DATE		
CAMA	MADN	06/03/15		
JOB NO.	DRAWING NO.	REV.		
A067772	G105			

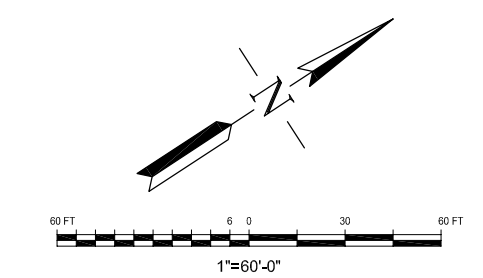
- LEGEND:**
-  DEPTH LESS THAN 6 FT
 -  WETLAND VEGETATION (AS OF MAY 2015)
 -  BUFFER AREA (10 FT FROM BULKHEAD, 25 FT FROM WETLANDS)
 -  PARCEL
 -  BULKHEAD
 -  BOROUGH DREDGING LIMIT
 -  SLIP DREDGING LIMIT (N.I.C.)
 -  DESIGN DREDGE DEPTH (6 FT MLLW CONTOUR)
 -  CONTOURS (1 FT INTERVAL)

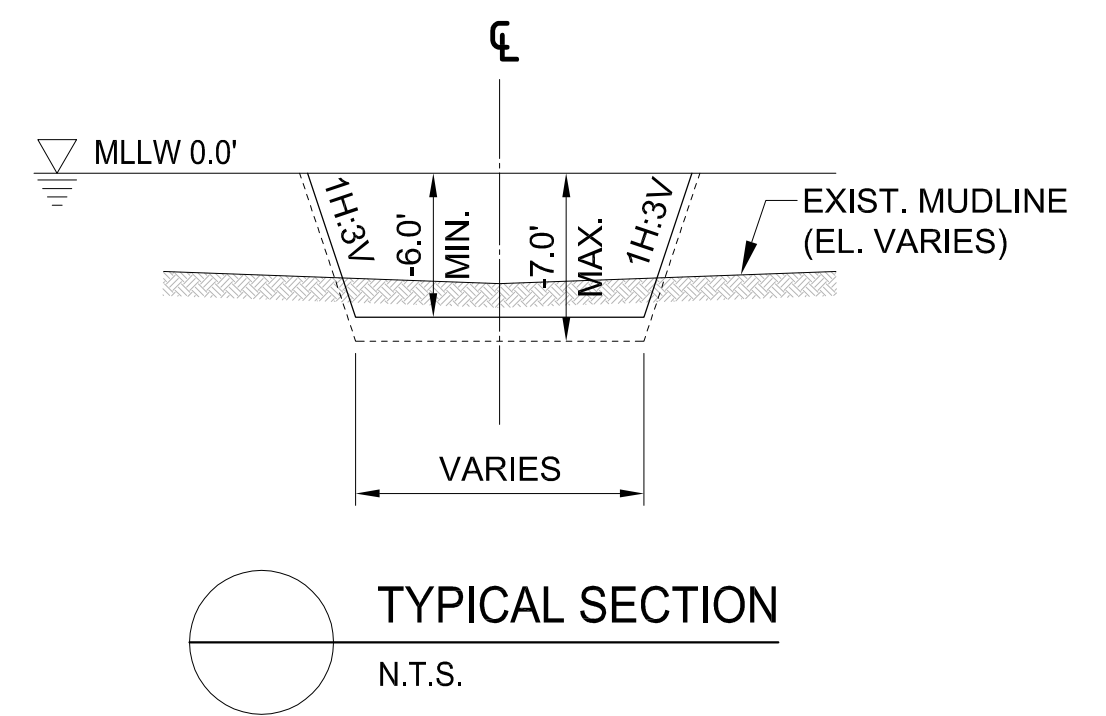

- NOTES:**
1. HYDROGRAPHIC SURVEY DATA COLLECTED BY HYDROGRAPHIC SURVEYS OF SEWELL, NJ BETWEEN 04/23/2015 AND 05/01/2015 AND CAN ONLY REPRESENT THE CONDITIONS AT THE TIME OF SURVEY.
 2. NO DREDGING SHALL OCCUR WITHIN 10 FEET OF THE BULKHEAD.
 3. NO DREDGING SHALL OCCUR WITHIN 25 FEET OF WETLANDS.
 4. ALL MAINTENANCE DREDGING SHALL HAVE 3:1 (H:V) SIDE SLOPE FROM LIMITS OF DREDGING AND BUFFER AREAS.
 5. ALL PROPERTY BOUNDARIES AND FEATURES HAVE BEEN PRODUCED FROM VARIOUS SOURCES AND IS TO BE USED FOR REFERENCE PURPOSES ONLY. THE DATA IS FOR INFORMATIONAL PURPOSES ONLY AND REPRESENTS ONLY THE APPROXIMATE RELATIVE LOCATION OF PROPERTY BOUNDARIES AND FEATURES. CONTRACTOR TO VERIFY IN FIELD.
 6. SLIP DREDGING AREA EXTENDS BETWEEN BOROUGH DREDGING LIMITS AND BULKHEAD.



REV	DATE	DESCRIPTION	BY	CHK
CLIENT				
BOROUGH OF STONE HARBOR 9508 SECOND AVENUE STONE HARBOR, NEW JERSEY				
CONSULTANT				
				
Website: www.cowi-na.com 20 E. Clementon Road, Suite 201N Gibbsboro, NJ 08026 Tel.: 856.248.1200 Fax: 856.248.1206				
PROJECT TITLE				
STONE HARBOR MAINTENANCE DREDGING				
ISSUED FOR BID				
DRAWING TITLE				
SANCTUARY BAY AND ACCESS CHANNEL				
SCALE		DESIGNED	APPROVED	
1" = 60'-0"		MADN		
DRAWN		CHECKED	DATE	
CAMA		MADN	06/03/15	
JOB NO.		DRAWING NO.		REV.
A067772		G106		

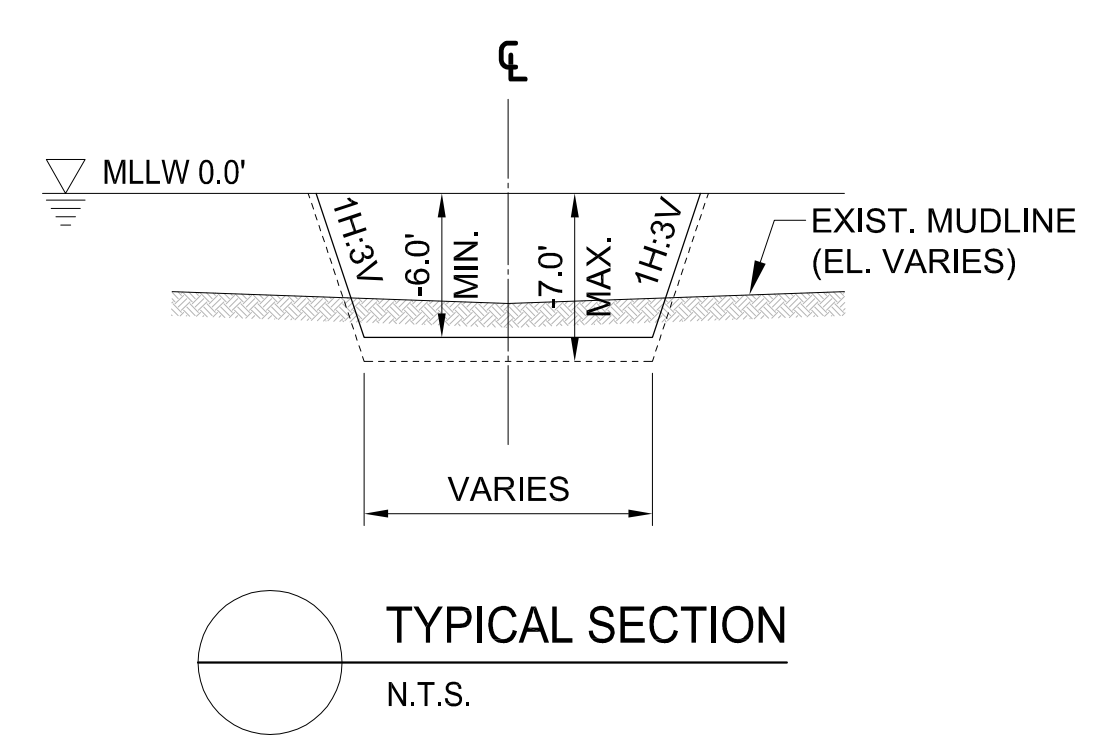
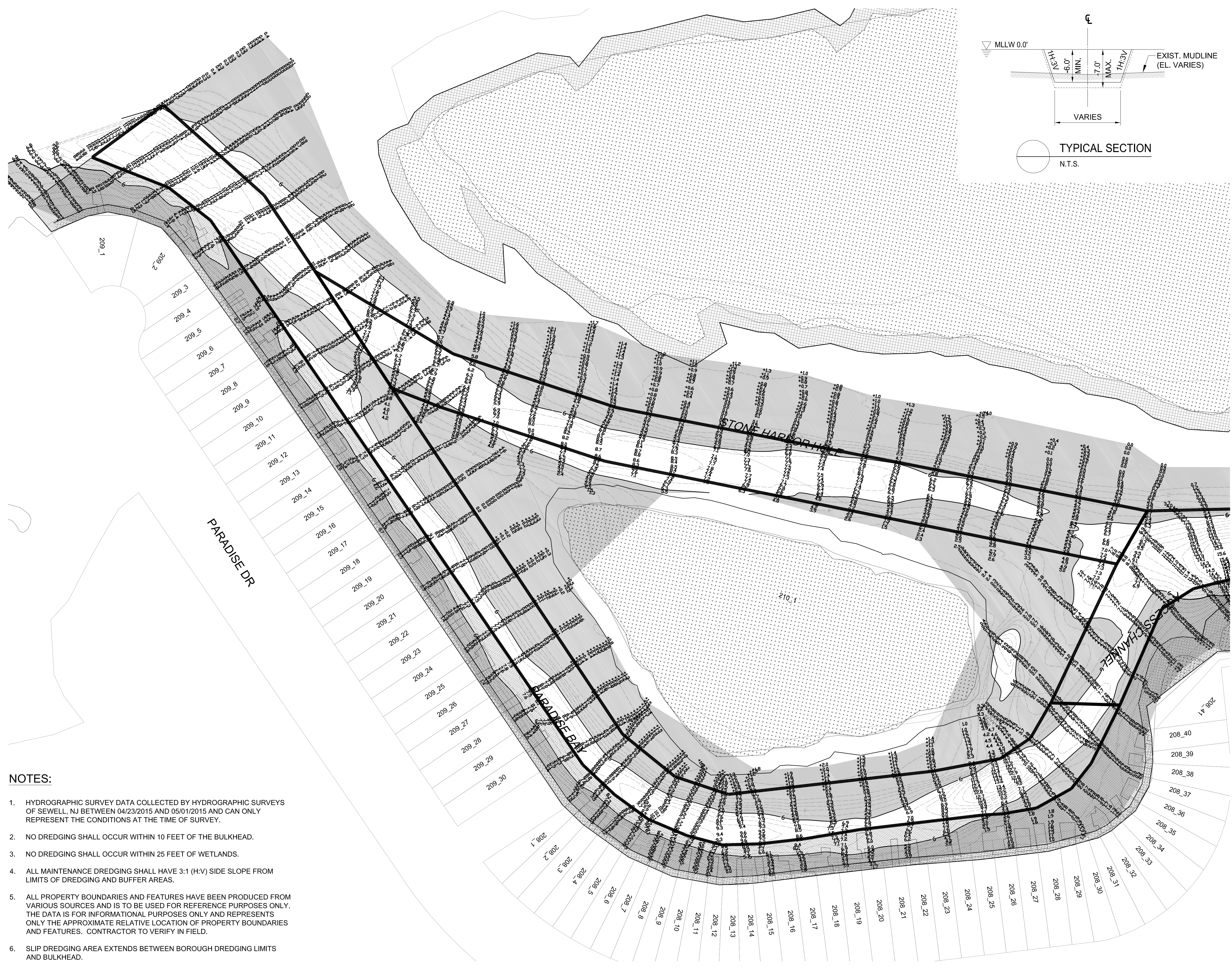

- LEGEND:**
- DEPTH LESS THAN 6 FT
 - WETLAND VEGETATION (AS OF MAY 2015)
 - BUFFER AREA (10 FT FROM BULKHEAD, 25 FT FROM WETLANDS)
 - PARCEL
 - BULKHEAD
 - BOROUGH DREDGING LIMIT
 - SLIP DREDGING LIMIT (N.I.C.)
 - DESIGN DREDGE DEPTH (6 FT MLLW CONTOUR)
 - CONTOURS (1 FT INTERVAL)

- NOTES:**
1. HYDROGRAPHIC SURVEY DATA COLLECTED BY HYDROGRAPHIC SURVEYS OF SEWELL, NJ BETWEEN 04/23/2015 AND 05/01/2015 AND CAN ONLY REPRESENT THE CONDITIONS AT THE TIME OF SURVEY.
 2. NO DREDGING SHALL OCCUR WITHIN 10 FEET OF THE BULKHEAD.
 3. NO DREDGING SHALL OCCUR WITHIN 25 FEET OF WETLANDS.
 4. ALL MAINTENANCE DREDGING SHALL HAVE 3:1 (H:V) SIDE SLOPE FROM LIMITS OF DREDGING AND BUFFER AREAS.
 5. ALL PROPERTY BOUNDARIES AND FEATURES HAVE BEEN PRODUCED FROM VARIOUS SOURCES AND IS TO BE USED FOR REFERENCE PURPOSES ONLY. THE DATA IS FOR INFORMATIONAL PURPOSES ONLY AND REPRESENTS ONLY THE APPROXIMATE RELATIVE LOCATION OF PROPERTY BOUNDARIES AND FEATURES. CONTRACTOR TO VERIFY IN FIELD.
 6. SLIP DREDGING AREA EXTENDS BETWEEN BOROUGH DREDGING LIMITS AND BULKHEAD.

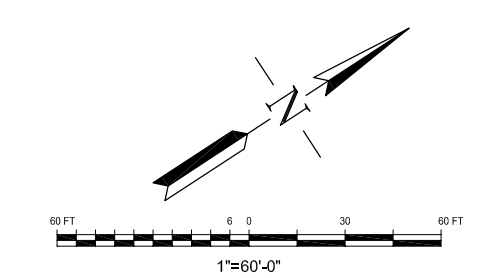

REV	DATE	DESCRIPTION	BY	CHK
CLIENT				
BOROUGH OF STONE HARBOR 9508 SECOND AVENUE STONE HARBOR, NEW JERSEY				
CONSULTANT				
Website: www.cowi-na.com 20 E. Clementon Road, Suite 201N Gibbsboro, NJ 08026 Tel.: 856.248.1200 Fax: 856.248.1206				
PROJECT TITLE				
STONE HARBOR MAINTENANCE DREDGING				
ISSUED FOR BID				
DRAWING TITLE				
PARADISE BAY, STONE HARBOR HOLE, AND ACCESS CHANNEL				
SCALE		DESIGNED	APPROVED	
1" = 60'-0"		MADN		
DRAWN		CHECKED	DATE	
CAMA		MADN	06/03/15	
JOB NO.	DRAWING NO.			REV.
A067772	G107			

GENERAL NOTES:

1. LIMIT, LOCATION, AND EXTENT OF STRUCTURES ARE APPROXIMATE. CONTRACTOR TO VERIFY IN FIELD.
2. EFFLUENT DISCHARGE AREA TO BE ENCLOSED WITH TURBIDITY CURTAIN.
3. FLOATING DOCKS, PIERS, PILINGS, AND VESSEL NOT SHOWN. VESSELS WITHIN THE MARINA MAY BE PRESENT UNTIL NOV 15. ON OR ABOUT NOVEMBER 15, THE OWNER WILL START TO REMOVE FLOATING DOCKS FROM THE STONE HARBOR MARINA AND PLACE UPLAND FOR TEMPORARY STORAGE
4. OWNER AND CONTRACTOR TO IDENTIFY LOCATION OF EFFLUENT DISCHARGE WITHIN THE EFFLUENT DISCHARGE AREA. OWNER IS RESPONSIBLE FOR PROVIDING SUFFICIENT EFFLUENT DISCHARGE AREA.
5. TRUCK TRAFFIC PROHIBITED ON 80TH STREET.
6. STORAGE AND STAGING WITHIN THE ACCESS AREA IS PROHIBITED.

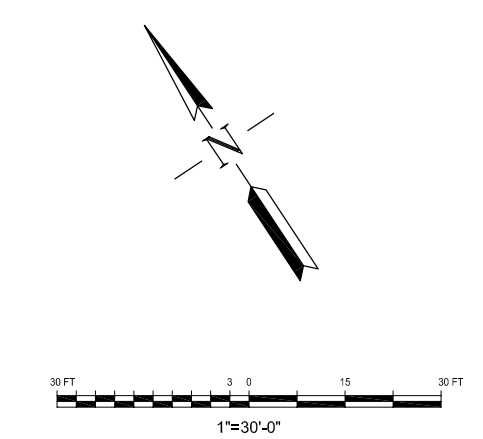

A	7/17/15	REVISED DEWATERING AREA LIMITS	MADN	
REV	DATE	DESCRIPTION	BY	CHK

CLIENT
 BOROUGH OF STONE HARBOR
 9508 SECOND AVENUE
 STONE HARBOR, NEW JERSEY

CONSULTANT
COWI Marine
 North America
 20 E. Clementon Road, Suite 201N
 Gibbsboro, NJ 08026
 Website: www.cowi-na.com Tel.: 856.248.1200
 Fax: 856.248.1206

PROJECT TITLE
 STONE HARBOR MAINTENANCE DREDGING

ISSUED FOR BID
 DRAWING TITLE
 TEMPORARY DEWATERING AREA

SCALE 1"=30'-0"	DESIGNED MADN	APPROVED
DRAWN CAMA	CHECKED MADN	DATE 06/03/15
JOB NO. A067772	DRAWING NO. G108	REV.

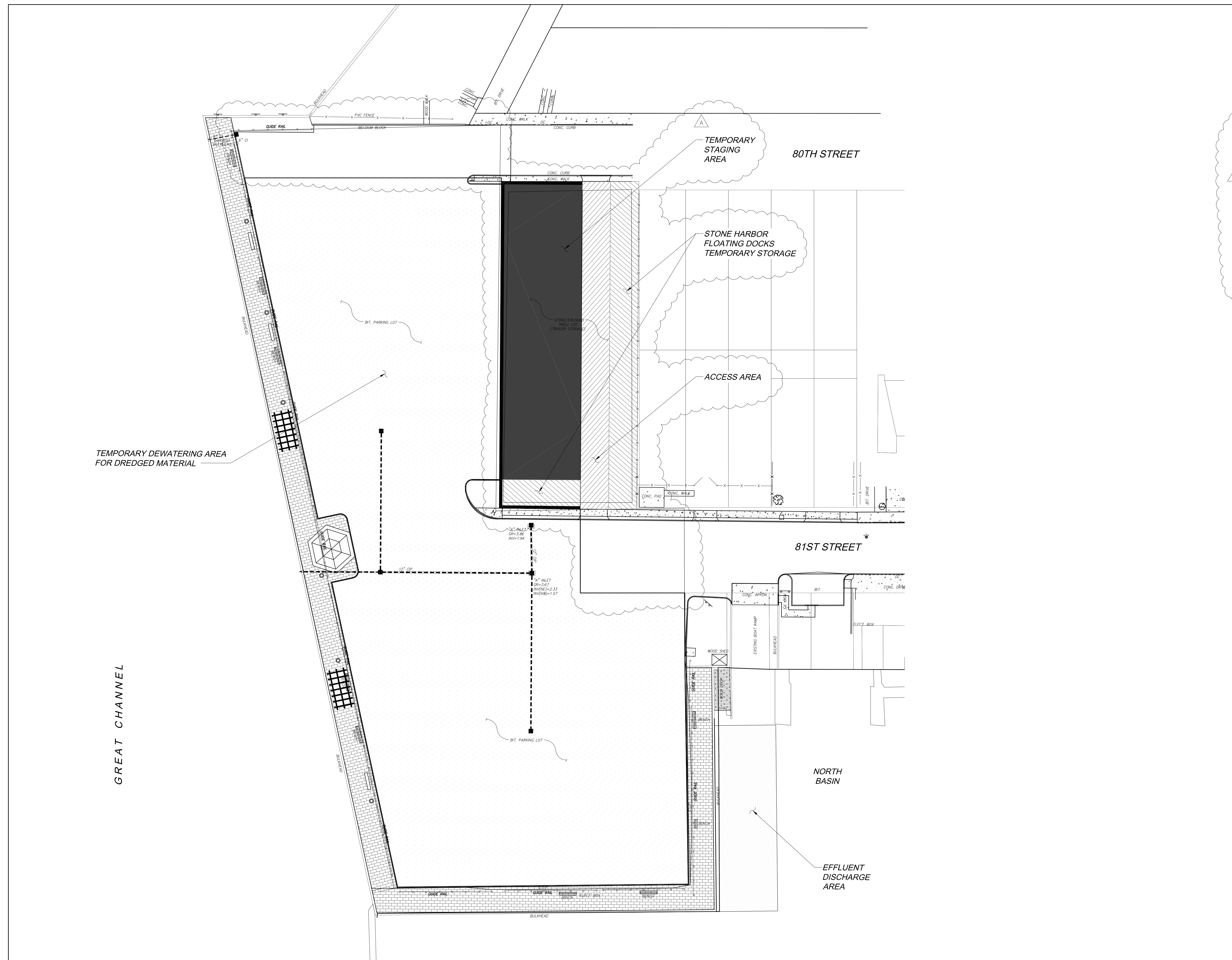

TEMPORARY DEWATERING AREA FOR DREDGED MATERIAL

TEMPORARY STAGING AREA

STONE HARBOR FLOATING DOCKS TEMPORARY STORAGE

ACCESS AREA

80TH STREET

81ST STREET

NORTH BASIN

EFFLUENT DISCHARGE AREA

GREAT CHANNEL